

S.NO	CATALOG NUMBER	L	B	C	D
1	DLI750-4	6.50 [165]	4	8	1.57 [40]
2	DLI750-4I	6.50 [165]	4	8	1.57 [40]
3	DLI750-6	10.25 [260]	6	12	1.66 [42]
4	DLI750-6I	10.25 [260]	6	12	1.66 [42]
5	DLI750-8	13.50 [343]	8	16	1.66 [42]
6	DLI750-8I	13.50 [343]	8	16	1.66 [42]

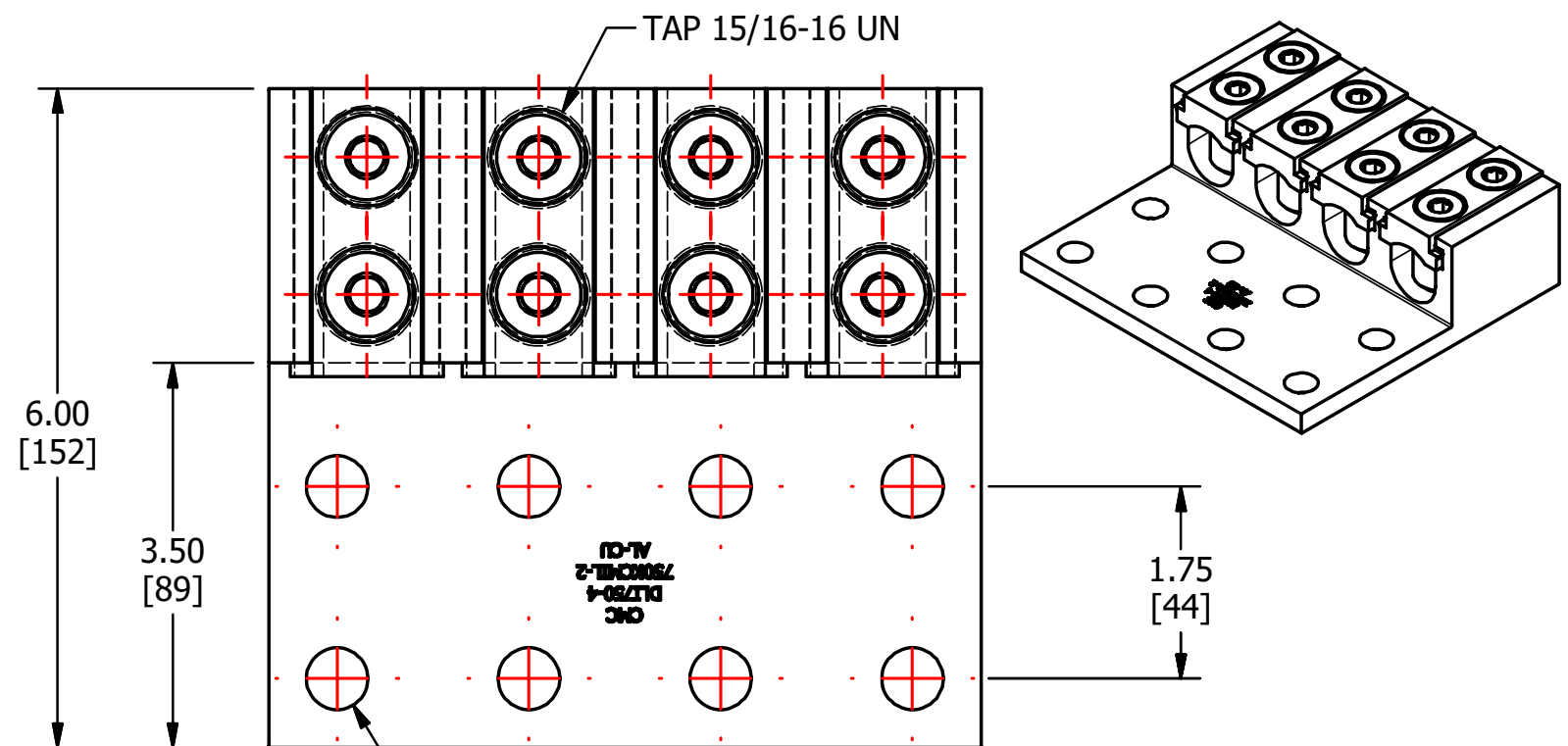

SCREWS ARE SUPPLIED WITH CONNECTOR AND COMES FULLY ASSEMBLED.

.56 DIA.  
[14]  
(C PLACES)

1.75 [44] TYP.  
.63 [16] .63 [16]

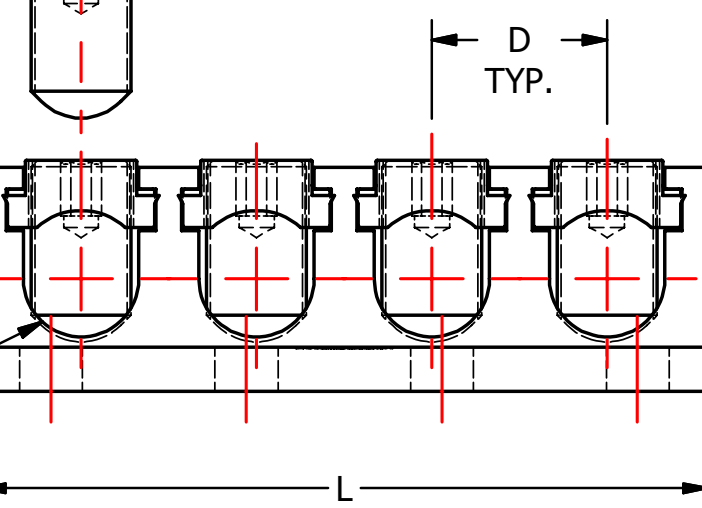

MATERIAL: ALUMINUM  
CONDUCTOR RANGE - 750KCMIL-2  
(AL-CU)

					TO ORDER CMC PRODUCTS CALL 1-513-860-4455	DRAWN BY: TS 08-19-19	NAME OF PART: LAY-IN LUG ASSEMBLY	CAT. NO.: SEE TABLE
					FOR PRODUCT INFO: <a href="http://www.cmclugs.com">http://www.cmclugs.com</a>	CHECKED BY:	DWG NO: C58701589-S (CHARTED)	A
A	NEW DRAWING CREATED		08-19-19	TS		DRAWING NOT TO SCALE		SHEET NO: 1 OF 1
REV.	DESCRIPTION	ECN	DATE	INIT.				

THIS INFORMATION IS PROPRIETARY TO CONNECTOR MFG. CO. AND IS NOT TO BE DISCLOSED OUTSIDE OF CONNECTOR MFG. CO. WITHOUT A CONFIDENTIALITY AGREEMENT



**CONNECTOR MANUFACTURING CO.**

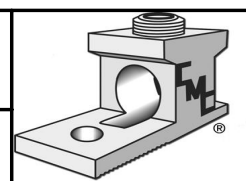

HAMILTON, OHIO